

STAPLE

NATIONAL SENIOR CERTIFICATE	
GRADE 12	
DATE:	MAY/ JUNE 2024
SUBJECT:	ENGINEERING GRAPHICS AND DESIGN
PAPER:	2
MARKS:	100
TIME:	3 Hours
NUMBER OF PAGES:	6

## INSTRUCTIONS AND INFORMATION

1. This paper consists of FOUR questions.
2. Answer ALL the questions.
3. ALL drawings are in third-angle orthographic projection, unless otherwise stated.
4. ALL drawings must be prepared using pencil and instruments, unless otherwise stated.
5. ALL answers must be drawn accurately and neatly.
6. ALL questions must be answered on the question paper, as instructed.
7. ALL pages must be placed in numerical order and stapled in ONLY the TOP LEFT CORNER, regardless whether the question was answered or not.
8. Time management is essential in order to complete all the questions.
9. Print your examination number in the provided block on each page.
10. Dimensions or detail not indicated must be estimated according to good proportions.

FOR OFFICIAL USE ONLY															
QUESTION	MARK OBTAINED			½	SIGN	MODERATED			½	SIGN	RE-MARKING			½	SIGN
1															
2															
3															
4															
TOTAL															
	2	0	0			2	0	0			2	0	0		



SOUTH AFRICAN COMPREHENSIVE ASSESSMENT INSTITUTE  
 SUID-AFRIKAANSE KOMPREENSIEWE ASSESSERINGSINSTITUUT

FINAL CALCULATED MARK	CHECKED
<u>100</u>	

CENTRE NUMBER	
CENTRE NUMBER	
IDENTIFICATION NUMBER	
IDENTIFICATION NUMBER	
EXAMINATION NUMBER	
EXAMINATION NUMBER	1

STAPLE

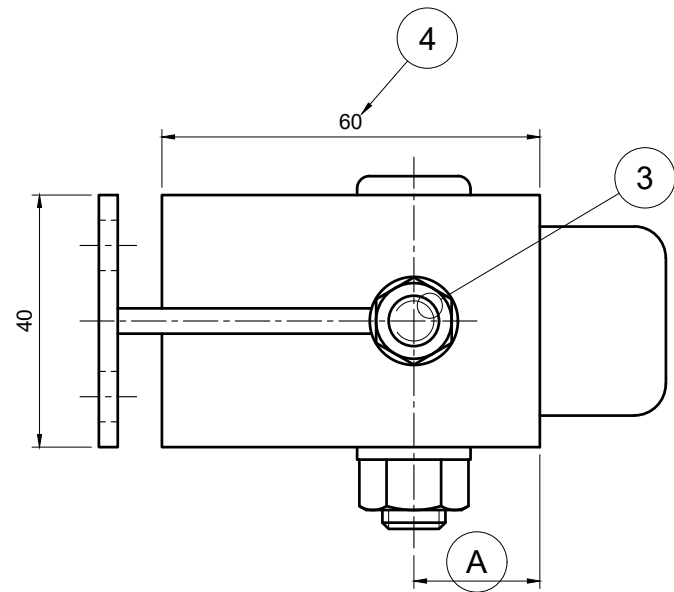

VIEW 1

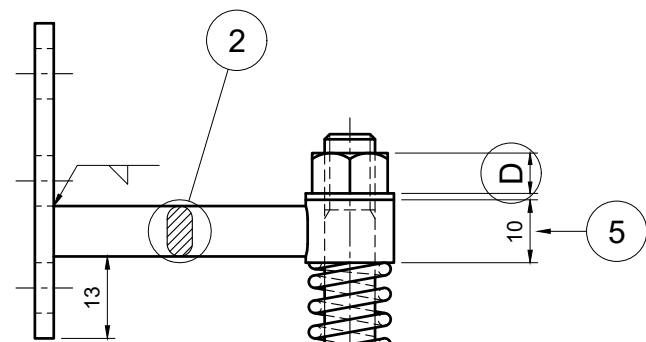

VIEW 2

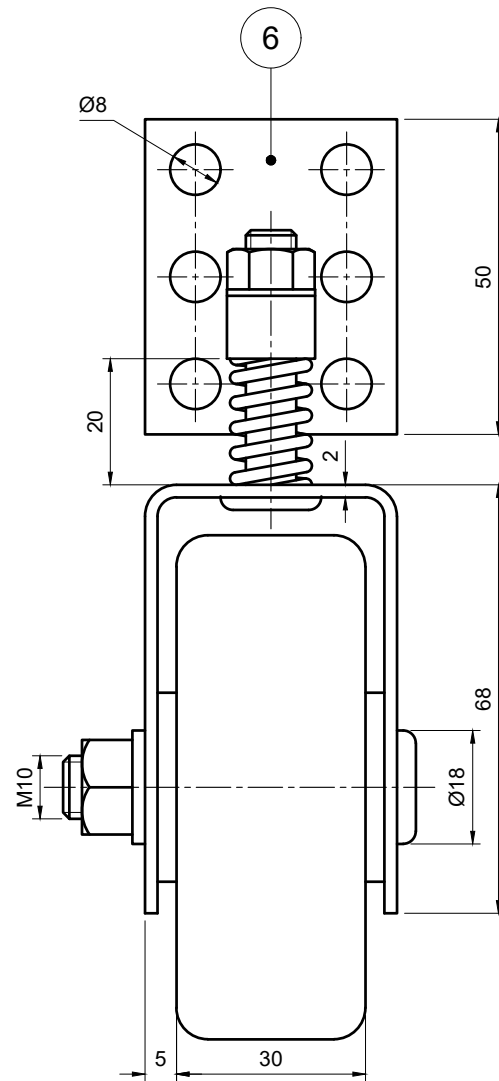

VIEW 4

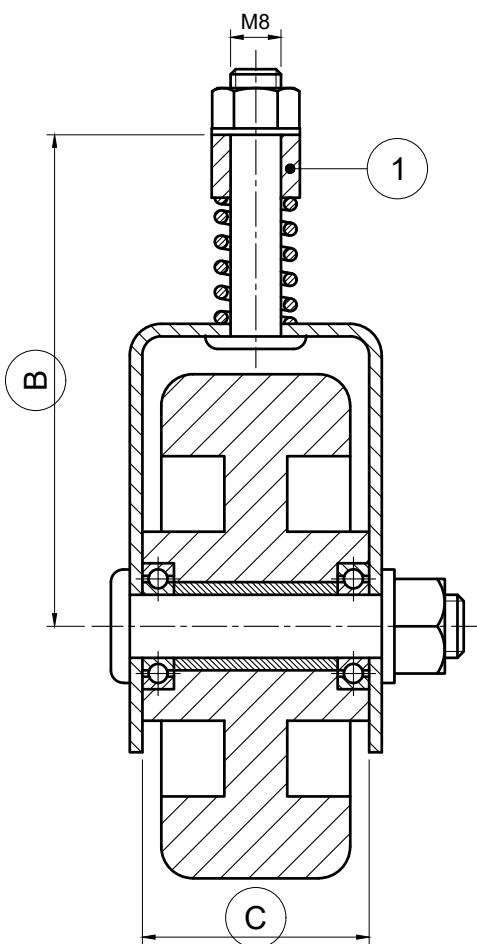

VIEW 3

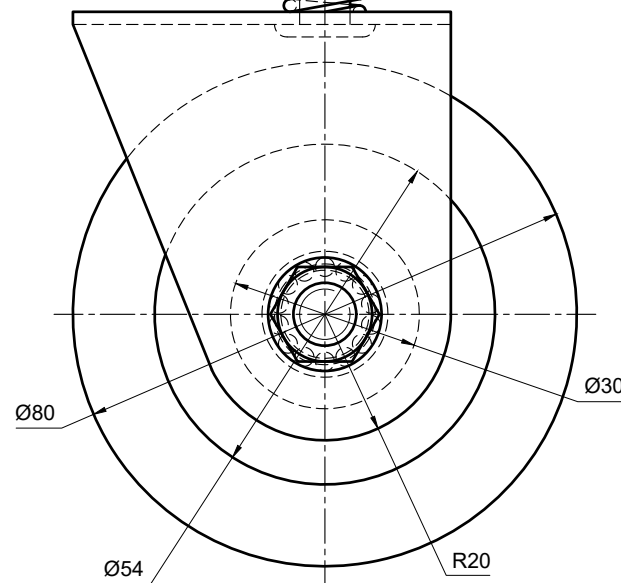

DRAWN:	PIETER	DATE:	2023/08/07
CHECKED:	MORNÉ	DATE:	2023/08/11
APPROVED:	TENDAI	DATE:	2023/08/16
UNLESS OTHERWISE SPECIFIED, ALL TOLERANCES ARE ±0,102		ALL DIMENSIONS ARE IN MILLIMETRES	
DRAWING PROGRAM:	AUTOCAD 2022	QUANTITY:	150 CASTOR WHEELS
DRAWING NUMBER:	EGD-P2B	SCALE:	1 : 2

**NEW DAWN**  
ENGINEERING

105 DORP STREET,  
POTCHEFSTROOM, 1012  
086 799 8569  
www.ndawnengineering.co.za

TITLE:  
**SPRING LOADED CASTOR WHEEL ASSEMBLY**

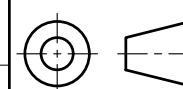

**QUESTION 1 MECHANICAL ANALYTICAL**

**Given:**  
Four views of a spring loaded castor wheel assembly, a title block and a table of questions. The drawing is not presented to the indicated scale.

**Instructions:**  
Complete the table below by neatly answering the questions, which refer to the accompanying drawing, title block and mechanical content. **[30]**

QUESTIONS		ANSWERS	
1	Which company is responsible for the drawing?	1	
2	On what date was the drawing approved?	1	
3	What is the drawing number?	1	
4	What orthographic projection system has been used?	1	
5	If VIEW 1 is the top view, what would VIEW 4 be called?	1	
6	How many different size nuts are used in the assembly?	1	
7	What does the symbol Ø indicate?	1	
8	What does the abbreviation AF stand for?	1	
9	Determine the complete dimensions at:	A:	1
		B:	1
		C:	1
10	Name the feature at 1.	1	
11	Name the type of section at 2.	1	
12	Name the encircled feature on the shaft at 3.	1	
13	If the drawing was drawn to a scale 1 : 5, what would the dimension at 4 read?	1	
14	If a standard nut is used, determine the height of the M8 nut at D.	2	
15	With reference to the welding symbol on VIEW 2, what type of weld should be used?	1	
16	With reference to the given tolerance, determine the minimum dimension at 5.	2	
17	Complete the cutting plane on VIEW 2 for VIEW 3, and label it S-S.	3	
18	In the space below (ANSWER 18), and with reference to the MOUNTING PLATE at 6, draw, in neat freehand, the SANS 10111 conventional representation for the given holes on a LINEAR PITCH.	4	
19	In the space below (ANSWER 19), draw, in neat freehand, the SANS 10111 conventional representation of a COIL SPRING.	3	
<b>TOTAL:</b>		<b>30</b>	

ANSWER 18: LINEAR PITCH

ANSWER 19: COIL SPRING

EXAMINATION NUMBER

EXAMINATION NUMBER

2



**QUESTION 2 LOCI (CAM)**

**Given:**

- The camshaft of a cam and the detail of a wedge shape follower at the maximum displacement.
- The position of centre point P on the drawing sheet.

**Specifications:**

- The minimum distance from the cam profile to the center of the cam shaft = 17 mm
- Rotation = anti-clockwise

**Motion:**

The cam rotates at constant velocity, imparting the following motion to the follower:

- Over the first 90° the follower moves to the right 40 mm with uniform acceleration and retardation
- It moves a further 18 mm to the right over the next 45° with uniform motion
- Over the next 45° the follower remains in rest
- It returns to the original position with simple harmonic motion over the remainder of the rotation.

**Instructions:**

- Use centre point P and draw, to a scale of 1 : 1, the given follower and cam shaft at the maximum displacement.
- Draw, to a rotational scale of 108 mm = 360° and a displacement scale of 1 : 1, the complete displacement graph for the given motion.
- Label the displacement graph and include the rotational scale.
- Using the given position of the follower as 0°, project and draw the cam profile from the displacement graph.
- Show the direction of rotation with an arrow on the cam profile.
- Show ALL construction.

[38]

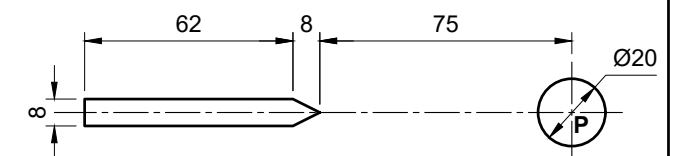

ASSESSMENT CRITERIA			
1	FOLLOWER + MAX. DIST. + CAMSHAFT + CENT. LINE	5½	
2	DISPLACEMENT GRAPH + CONSTRUCTION	16½	
3	CONSTR + DIRECTION	6	
4	PLOTTING + CURVES	10	
PENALTIES(-):			
<b>TOTAL:</b>		<b>38</b>	
EXAMINATION NUMBER			
			3

STAPLE

**QUESTION 3 ISOMETRIC DRAWING**

**Given:**

- The front view, top view and left view of a guide
- The position of point P on the drawing sheet

**Instructions:**

Using scale 1 : 1, convert the orthographic views of the guide into an isometric drawing.

- Use P as the starting point of the drawing.
- Show ALL construction.
- No hidden detail is required.

[39]

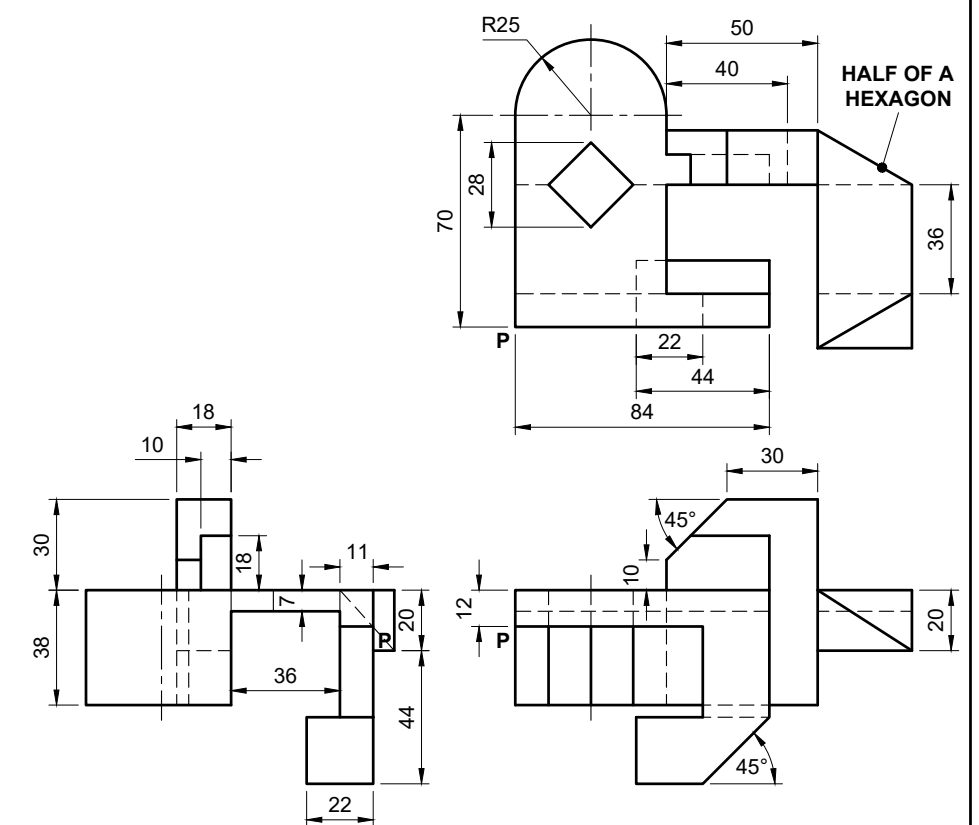

↓  
P

ASSESSMENT CRITERIA			
1	AUXILIARY VIEWS + PLACEMENT	2	
2	FRONT PART	15½	
3	BACK PART	16	
4	CIRCLE+ CENTRE LINES + CONSTRUCTION	5½	
PENALTIES(-):			
<b>TOTAL:</b>		<b>39</b>	
EXAMINATION NUMBER			
EXAMINATION NUMBER			4

**QUESTION 4 MECHANICAL DRAWING**

**Given:**

- The exploded isometric drawing of a v-belt drive assembly, showing the positions of the parts relevant to one another
- Orthographic views of each part of the v-belt drive assembly

**Instructions:**

- Answer this question on page 6,
- Draw, to a scale of 1 : 1 and in third angle orthographic projection, the following views of the assembled parts of the v-belt drive assembly:
  - 4.1 **A sectional front view** on cutting plane A-A, as seen from the direction of the arrow shown on the exploded isometric view. The cutting plane is shown on the left view of the bracket (part 3).
  - 4.2 **Only the right half of the left view**, by applying the convention of symmetry.

**NOTE:**

- Planning is essential.
- The drawing must comply with the *SANS 10111* guidelines.
- Show three faces for the M20 nut (part 1) on the left side of the gear (part 2), and two faces for the M20 nut (part 1) on the right side of the pulley (part 10) in the sectional front view.
- The bearing (part 6) must be drawn as a conventional representation.
- The surfaces marked **S** and **P** on the bearing (part 6), must align with the surface marked **S** on the bracket (part 3) and the surface marked **P** on the inside of the cover plate (part 4).
- No hidden detail is required.

[93]

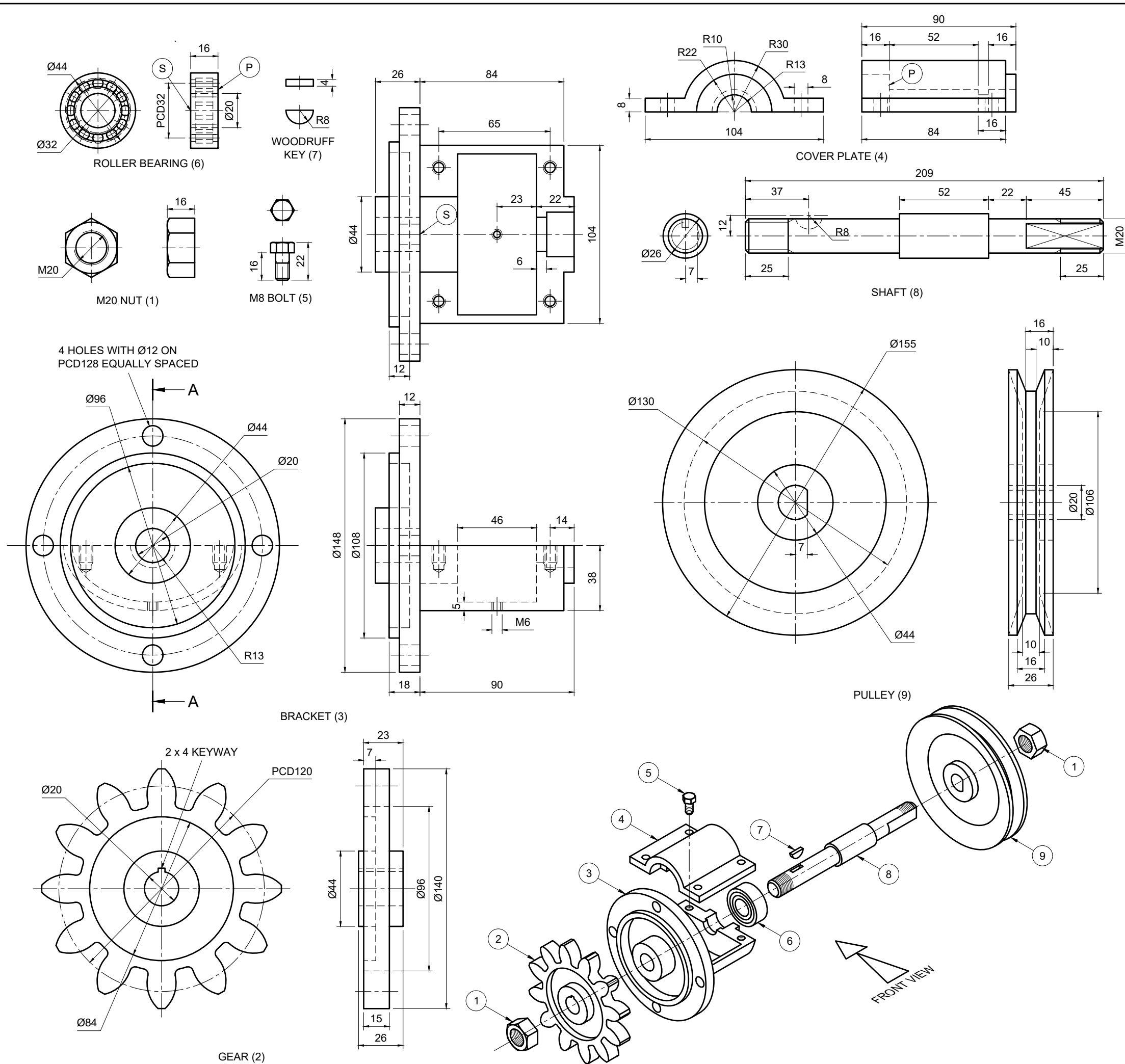

PARTS LIST		
#	PART NAME	QUANTITY
1	M20 NUT	2
2	GEAR	1
3	BRACKET	1
4	COVER PLATE	1
5	M8 BOLT	1
6	ROLLER BEARING	1
7	WOODRUFF KEY	1
8	SHAFT	1
9	PULLEY	1

MECH DRAUGHTING		SANDTON P.O. BOX 0028 010 102 3050
<b>V-BELT DRIVE ASSEMBLY</b>		
ALL DIMENSIONS ARE IN MILLIMETERS		

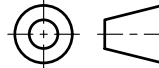

FOR OFFICIAL USE ONLY	
INCORRECT ORTHOGRAPHIC PROJECTION	
INCORRECT OVERALL SCALE	
INCORRECT HATCHING	
PARTS NOT ASSEMBLED	
TOTAL:	

ASSESSMENT CRITERIA				
LEFT VIEW				
1	SYMMETRY	1		
2	M20 NUT + GEAR	7		
3	BRACKET + PULLEY	1		
SUBTOTAL:		9		
SECTIONAL FRONT VIEW				
1	BRACKET + COVER PLATE	22		
2	SHAFT + KEY + BEARING	20		
3	GEAR	11½		
4	PULLEY	11½		
5	M20 NUT	8		
SUBTOTAL:		73		
GENERAL				
1	CENTER LINES	3		
2	ASSEMBLY	8		
SUBTOTAL:		11		
<b>TOTAL:</b>		<b>93</b>		
PENALTIES(-):				
<b>GRAND TOTAL:</b>				
EXAMINATION NUMBER				
EXAMINATION NUMBER				6