



SOUTH AFRICAN COMPREHENSIVE ASSESSMENT INSTITUTE
SUID-AFRIKAANSE KOMPREENSIEWE ASSESSERINGSINSTITUUT

Adult Basic Education and Training (ABET)

Summative Assessment

Mathematical Literacy: NQF Level 1

Examination Session: June 2024

Grand Total: 100 marks

Time: 3 hours

Number of Pages 20 pages

Learner Information

Candidate Number

Centre Name

Date



EXAMINATION RULES FOR CANDIDATES

1. Candidates are bound in all matters relating to the examination to obey the instructions of the chief invigilator. The chief invigilator, where relevant, determines the dress code.
2. Candidates must be identified before they are permitted to write an examination. Identity document must be produced when required. All candidates are to sign the attendance register.
3. Candidates will not be admitted to the examination room if they arrive an hour or more after the start of the examination. Candidates who have finished answering an examination paper within fifteen minutes of stopping time will not be allowed to leave the examination room, provided there are still candidates writing.
4. Candidates must occupy the places first allocated to them for the entire duration of the examination and for all other examination sessions, unless otherwise directed by the chief invigilator.
5. No explanation of examination questions may be asked or given by any person.
6. No candidate is allowed to leave the examination room within the first hour of the examination, except in an emergency and under supervision.
7. A candidate may only be allowed to leave the examination room in the case of an emergency or to go to the toilet, and in these cases, this must be done under supervision.
8. As soon as a candidate hands in his or her answer script, he or she must leave the examination room.
9. A candidate must carefully read and comply with the instructions, which appear in his or her question paper and the examination timetable.
10. A candidate is not allowed to assist another candidate or try to assist him or her or communicate with another candidate. Should this occur, it would constitute an irregularity. Invigilators are expressly forbidden from assisting candidates in the answering of questions.
11. All questions must be directed to the invigilator.
12. A candidate may not cause a disturbance in the examination room or behave in an improper or unseemly manner.
13. A candidate may not disregard the instructions of the invigilator or may not conduct themselves in a manner that conflicts with the instructions of the chief invigilator.
14. The following are not allowed next to the candidate in the examination room: suitcases, school bags, Walkman, CD players, cell phones, books, dictionaries, notes, sketches or paper other than the official examination material distributed by the chief invigilator. Slide-rules and non-programmable, silent calculators may be used, unless expressly prohibited in the question paper. Pens, erasers, rulers, etc. should be kept in transparent containers/bags. No borrowing is allowed. Wristwatch alarms must be switched off.
15. Candidates should be informed that the possession of notes constitutes an irregularity regardless of whether the notes are used. The excuse that a candidate has forgotten or was not aware that he or she has the unauthorised material listed in paragraph 14 in his or her possession will not be accepted.
16. No examination answer books (or part of an answer book), whether used or unused, may be removed from the examination room. Should this occur, it will be considered an irregularity and the candidate will receive NO credit for the examination. Should a candidate write the wrong subject or wrong grade of a subject, this will be a technical irregularity and will lead to the candidate's results being blocked/cancelled/delayed.
17. Should a candidate miss an examination due to illness, a valid doctor's certificate must be given to the chief invigilator. A Certificate will not be awarded to candidates who miss an examination.

Any candidate who disregards these rules or the instructions of the chief invigilator or his / her assistants, will have committed an offence in terms of the Regulations [Regulation 6 2(a) and (b)] or a contravention of the Rules [Rule 3(2)].



INSTRUCTIONS

1. Answer **ALL** the questions in the space provided.
2. Write in blue or black pen only.
3. Calculators may be used but **ALL** calculations must be shown.
4. Round off your answers to **TWO** decimal places, unless otherwise stated.
5. Diagrams not drawn to scale.



Question 1

1.1 The population of Lesotho is 2 193 894 and the population of South Africa is 61 532 760.

1.1(a) Write the sum of the two countries' populations in words.

(2)

1.1b Express the population of Lesotho as a percentage of the South African population. Round off the answer to one decimal. Show working.

(2)

1.2 What is the place value of the underlined digit in the number; 48,736?

(1)

1.3 Write $(-7^6) \div (-7^4)$ as a single power. Show working.

(2)

1.4 Work out: $5^{-1} \times 5$

(2)

1.5 Round off 3 457 659 to the nearest million.

(1)

[10 marks]

Question 2 is on the next page.



Question 2

2.1 Simplify:

2.1(a) $\sqrt{50}$. Show working.

(2)

2.1(b) $\frac{5}{7} \div 3\frac{4}{7}$ Show working

(2)

2.2 Calculate: $[(4 - 9)^3 \times 5^4]^0 + (6 - (3)^4)$

(2)

2.3 Find the value of p : $4p \times \frac{1}{6} = 20$ Show working.

(2)

[8 marks]**Question 3 is on the next page.**

Question 3

3.1 Mr. Khuzwayo is a self-employed motor mechanic and has saved a total of R926 765 in his retirement savings with a financial institution. He will receive one third of the pension fund as a lump sum, which is not taxed.

3.1(a) How much will he receive as one third lump sum? Show working. Round to the nearest whole number.

(2)

3.1(b) Calculate amount left in the retirement savings after he takes his one third. Show working.

(2)

3.1(c) The amount in question 3.1(b) above is taxed at 25%. How much will remain in his retirement savings? Show working. Round of to the nearest whole number.

(2)

3.1(d) If he is paid a monthly amount of R4 200 from the remaining savings in question 3.1(c). How many years will the remaining pension fund last?

(2)

[8 marks]

Question 3 is on the next page.



Question 4

4.1 State whether the two statements below are True or False.

4.1a Doubling the height of a triangular prism is the same as doubling its volume.

(1)

4.1b There are 10 800 minutes in 7 days.

(1)

4.2 Chris took 3 hours from home to town, driving at a speed of 115 km/h.
Calculate the distance between his home and town. You may use the

formula; $Speed = \frac{Distance\ travelled}{Time\ taken}$ Show working.

(2)

4.3 In the diagram below ABCE is a rectangle with EF = 3.5 cm, FC = 2.5 cm and AE = 9 cm. What is the perimeter of ABCE? Show working.

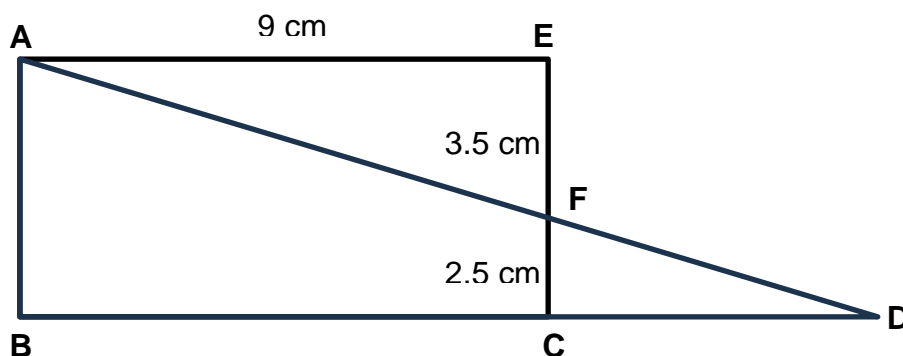

(2)

Question 4 continues the next page.

- 4.4 The diagram shows a circle with a radius of 6 units inside square PQRS. Calculate the area of the shaded part. Formula for area of circle: $A = \pi r^2$, where $\pi = 3.14$. Show working.

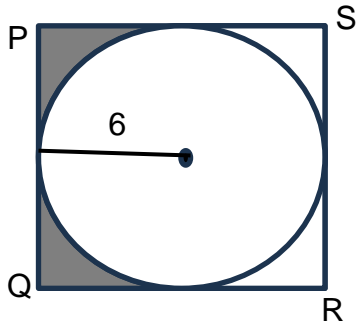

(3)

- 4.5 A ladder with a length of 5 m is placed at an angle against a wall. The bottom of the ladder is 3 m away from the wall. How far up the wall will the ladder reach? You may use the theorem of Pythagoras. Show working.

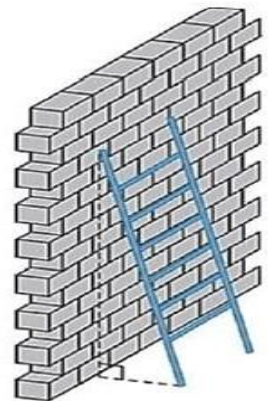

(3)

(12 marks)

Question 5 on the next page.

Question 5

Study the diagrams below and answer the questions.

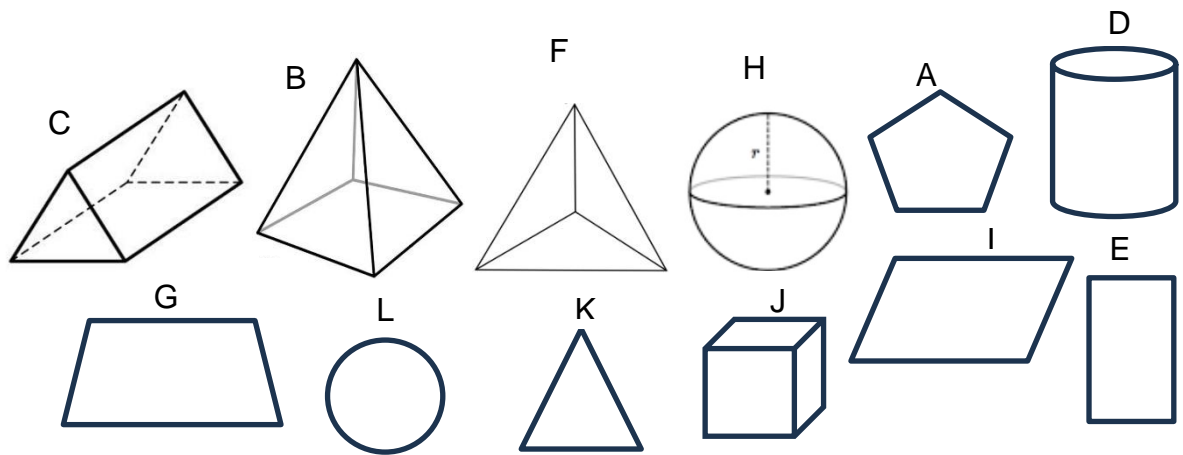

5.1 What is the name of diagram H?

(1)

5.2 Which two diagrams are the faces of diagram D?

(2)

5.3 True or false? Diagram B and diagram H are both 3-D objects.

(1)

5.4 Which diagram has only one pair of opposite sides parallel?

(1)
(5 marks)

Question 6 on the next page

Question 6

In the diagram below, MN and KL are straight lines which meet at Q.

AB and CD are parallel straight lines. Angle AQM = 80° and Angle KQB = 64° ,

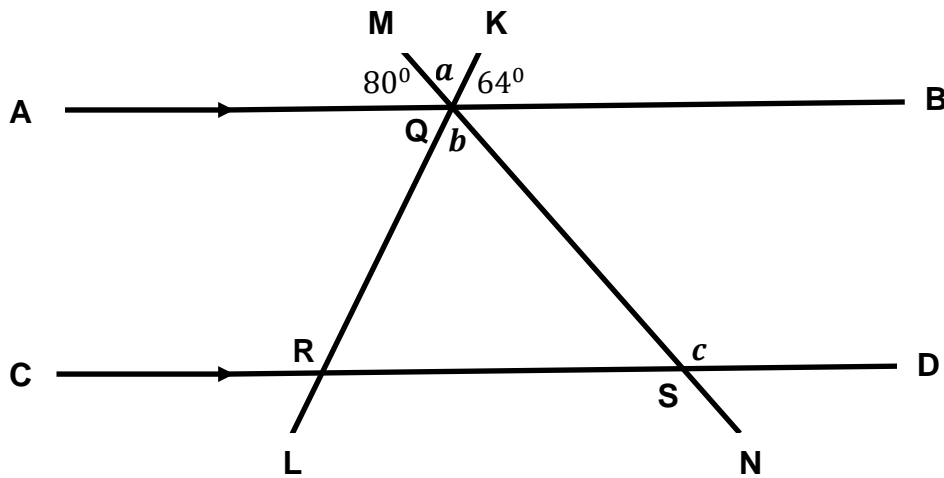

6.1 Calculate the value of a . Give a reason for each statement. Show working.

(3)

6.2 Find the value of b . Give a reason for each statement. Show working.

(2)

6.3 What is the value of c . Give a reason for each statement. Show working.

(3)

(8 marks)

Question 7 on the next page.



Question 7

- 7.1 Triangle ABC and triangle EDC are congruent. Answer the following questions below.

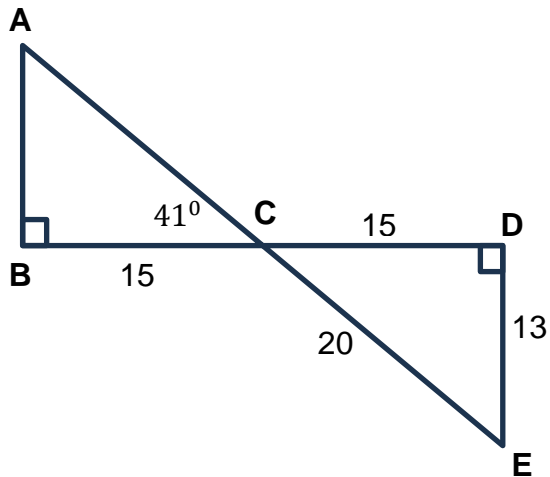

- 7.1(a) Calculate the length of AC. Show working.

(3)

Question 7 continues the next page.

7.2 The diagram below shows a parallelogram KLMN with KN = 15cm, LS = 12 cm and LR = 7cm.

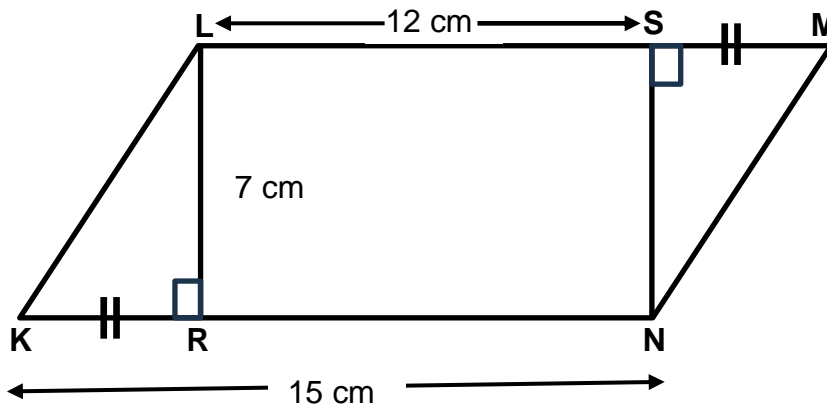

7.2(a) Find the area of KLMN. Show working. $Area \Delta = \frac{1}{2} \times base \times height$

(5)

7.3 On a map, the distance between Town A and Town B is 16 cm. Find the actual distance in kilometers from Town A and Town B. Use the scale, 1 cm : 50 000 cm. Show working.

(3)
(11 marks)

Question 8 is on the next page.



Question 8

- 8.1 The figure below shows a circle inside a semi-circle. Find the perimeter of the shaded part. Show working. Formula for circumference of a circle; $C = 2\pi r$, $\pi = 3.14$.

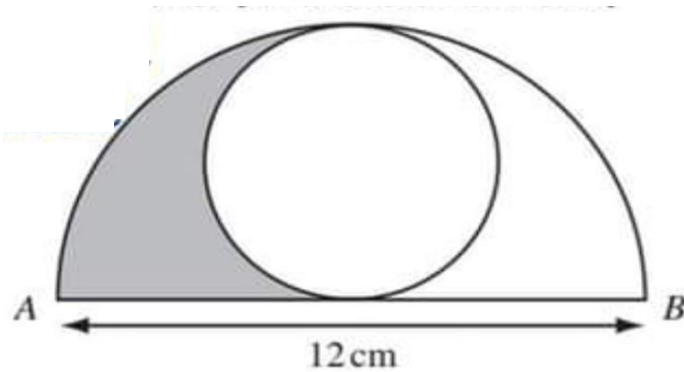

(4)

- 8.2 The object below is made up of two rectangular prisms. Calculate the volume of the object. Show working. Formula for volume of rectangular prism; $V = l \times b \times h$.

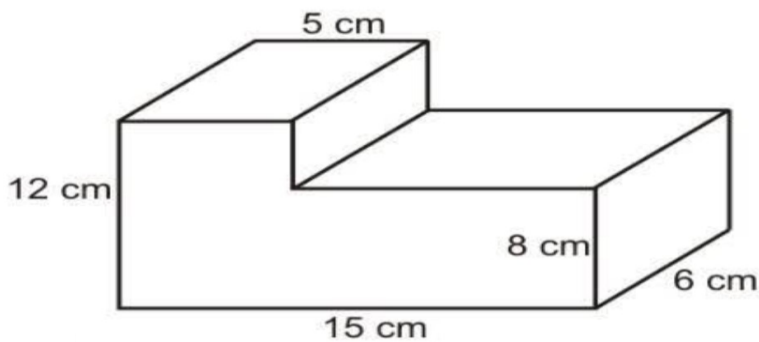

(3)

(7 marks)

Question 9 is on the next page.

Question 9

The stem and leaf diagram below represent marks in percentage obtained by AET level 4 candidates at a Centre for the SMME final examination.

Stem	Leaf
3	3 4 6 6 6
4	0 1 1 5 6 7 9 9
6	0 0 1 5 7
7	2 3 6 7

9.1 How many candidates wrote the examination?

(1)

9.2 What is the mode of the marks obtained?

(1)

9.3 Calculate the median of the marks. Show working.

(2)

9.4 Find the mean of the marks. Show working.

(2)

Question 9 continues the next page.

9.5 What is the range of the marks obtained? Show working.

(2)

9.6 Complete the Tally and Frequency table below, of marks obtained by candidates.

Class Interval	Tally	Frequency
30 – 49		
50 – 69	///	5
70 – 100	////	4

(2)

[10 marks]

Question 10 is on the next page.

Question 10

The double bar graph below represents the demand and production of five flavors of energy drinks in 500 ml cans, at a local manufacturing company. Study the diagram and answer the questions.

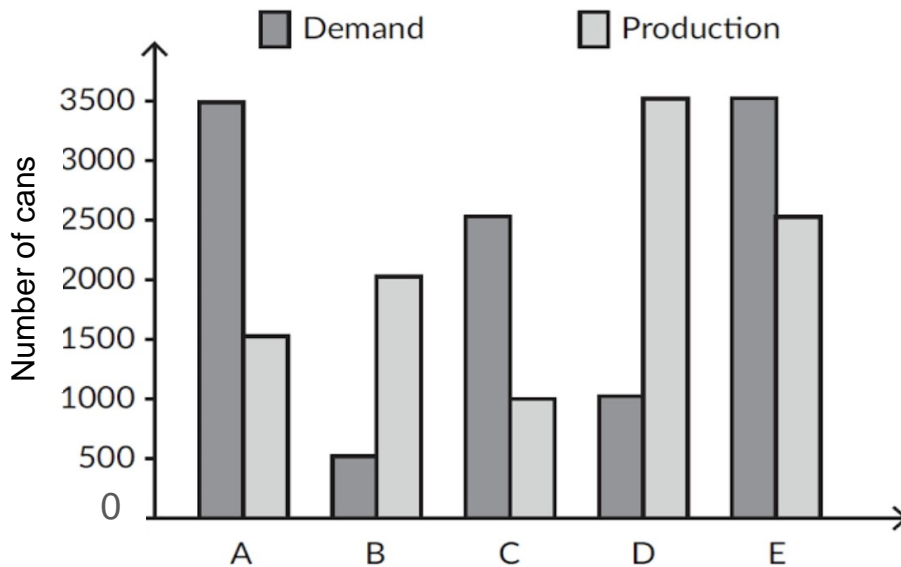

10.1 Provide an appropriate name for the horizontal (x) axis.

(1)

10.2 Which flavor was least produced?

(1)

10.3 Which two flavors were produced more than their demand?

(2)

Question 10 continues the next page.

10.4 How many more cans should be produced to cover the demand of flavor C?
Show working.

(2)

10.5 Write flavor A production as a percentage of its demand. Show working. Round off to the nearest whole number.

(2)
[8 marks]

Question 11 continues the next page.



Question 11

The table below indicates the number of road accidents in the five provinces in 2007. Draw a bar graph to represent the data in the table. Clearly label your axes and give your graph a suitable title.

Province	Gauteng	Limpopo	Mpumalanga	Free State	North West
Road Accidents	3 657	1 418	1 694	1 042	1 303

Title: _____



(5)
[5 marks]

Question 12 continues the next page.



Question 12

12.1 A six-sided die is thrown once. Determine the probability of rolling the number 3.



(2)

12.2 What is the probability of getting the number 2 after rolling a die 500 times? Show working. Round off to the nearest whole number.

(2)

12.3 A coin is tossed twice, complete the tree diagram of all possible outcomes below.

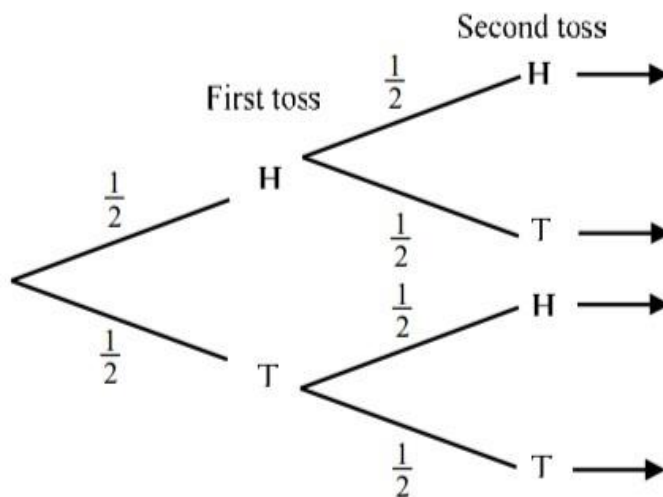

(4)
[8 marks]

GRAND TOTAL: 100 MARKS
END OF EXAMINATION



For Office Use Only

Question	Maximum Mark	Learner's Mark
1	10	
2	8	
3	8	
4	12	
5	5	
6	8	
7	11	
8	7	
9	10	
10	8	
11	5	
12	8	
Total	100	
Percentage		
Final Grading		

Name and Surname of Marker

Date of Marking

Name and Surname of Moderator

Date of Moderation

Name and Surname of Umalusi Official

Date of Moderation
